

## Propeller Anemometer 27106T

S17100

سنسور سنجش سرعت باد (پروانه ای) - یونگ

کد سفارش

- Low threshold precision air velocity sensor
- Fast response helicoid propeller
- Vertical air measurements

### Description

The Propeller Anemometer is a precision, single axis wind measuring instrument. The anemometer utilizes a fast response helicoid propeller and high quality tach-generator transducer to produce a DC voltage that is linearly proportional to air velocity. Airflow from any direction may be measured, however, the propeller responds only to the component of the air flow which is parallel to its axis of rotation. Off-axis response closely approximates a cosine curve with appropriate polarity; with perpendicular air flow, the propeller does not rotate.

The output signal is suitable for a wide range of signal translators and data logging devices. The Model 27106T with carbon fiber thermoplastic (CFT) propeller offers high sensitivity and durability.



### Installation

Generally, the sensor should be oriented with the propeller facing the predominant flow of air being measured. In some cases it is appropriate to orient the sensor so the predominant air flow is perpendicular to the propeller such as in applications measuring the vertical component of wind. Note that off-axis response increases the effective threshold and distance constant. **For vertical measurements mount the instrument so the propeller faces upward.** This helps prevent moisture or dirt from entering around the propeller hub and potentially contaminating the bearings.

The sensor mounts to **3/4 inch standard pipe**. A rugged cable connector provides both electrical and mechanical connection. A dustcap is provided to protect the connector when the instrument is removed. The sensor measures both forward and reverse air flow. In applications measuring vertical air flow, the sensor is usually connected so downdrafts produce a negative signal, updrafts a positive signal (Pin B = positive).

Output from the tech-generator should be connected to a load impedance of 10k ohms or higher.

### Maintenance

Given proper care, the Gill Propeller Anemometer should provide years of service. Components are conservatively rated and require little maintenance. The only parts likely to need replacement due to normal wear are the precision ball bearings and the tach-generator. The replacement procedures are best performed in a service facility and only by qualified technicians. If service facilities are not available, return the instrument to the factory.

### Dimensional drawing

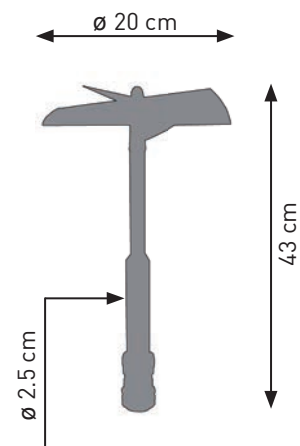

# Propeller Anemometer 27106T

S17100

## Specification

Characteristic	Description / Value
Measurement range	0 ... 40 m/s (axial flow) 0 ... 35 m/s (all angles)
Accuracy	± 1% (0.0049 m/s per rpm)
Slope	18 m/s/V
Output voltage	Analog DC voltage proportional to axial wind component. Polarity reverses with reverse rotation. 1800 rpm (500 mV) = 9 m/s ± 1 V = ± 18 m/s
Threshold sensitivity	0.4 m/s
Operating temperature	-50 ... 50°C
Propeller	4-blade helicoid propeller molded of carbon fiber thermoplastic
Dimensions	Length: 43 cm, housing diameter: 2.5 cm, propeller diameter: 20 cm
Weight	0.5 kg
Mounting	3/4 " pipe thread adapter
Manufacturer	Gill / Young

## Sensor Connection to Ammonit Meteo-40 Data Logger

Sensor	Plug Pin No.	Ammonit Wire Colour	Meteo-40 Analog Voltage
Vertical Wind Speed Output Voltage	B	white red	A
	A	blue black	B

Connect the shield logger-sided to Ground (GND)

Cable LiYCY 4 x 0.25 mm<sup>2</sup>

**Note:**

In case of ascending air flow Pin B of the anemometer plug is the positive pole.

## Sensor connection diagram to Ammonit Meteo-40 data logger

Anemometer Propeller 27106T  
Vertical Wind Speed

